

VersaSlider 3 instruction manual

V1.3 06/04/2018 contact support@workshopscience.com for information or inquiries

Thank you for your purchase! Before using the VersaSlider 3, it is important to familiarize yourself with some of the controls and features in order to prevent any damage. This manual will go over the following topics:

- Controls / operation
- Safety
- Troubleshooting

Controls / operation

Operating the VersaSlider 3 is very easy thanks to the simple and intuitive user interface. There are two main components to it: a toggle switch and a rotating dial with an integrated pushbutton.

This is the on/off switch. When in the upwards position, the VersaSlider will turn on and start initializing. After 5s, the unit is ready for use.

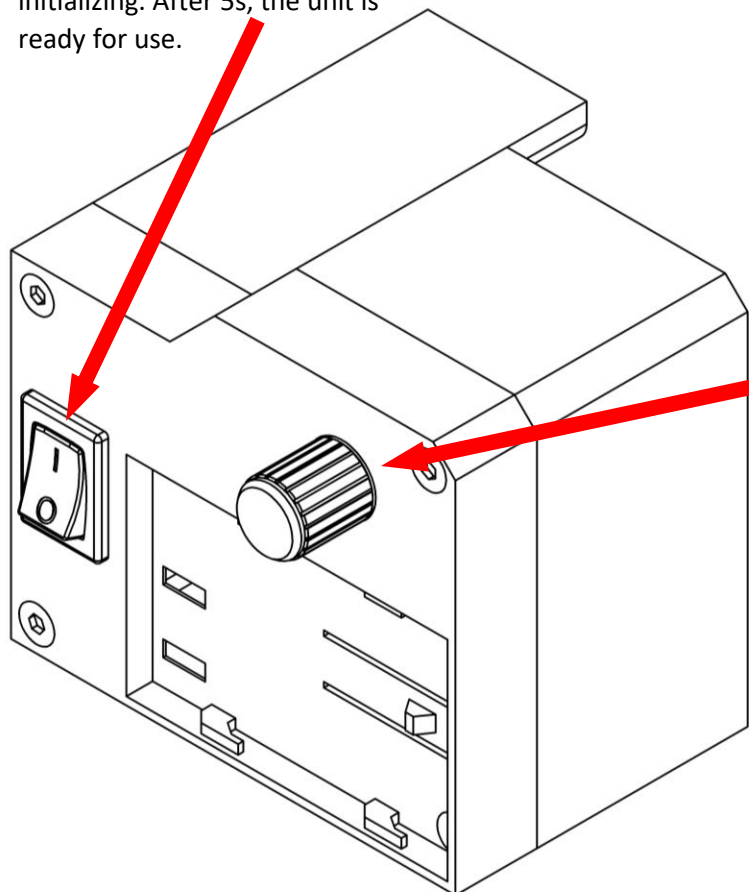

This is the speed dial. Rotate it clockwise to increase the speed and anticlockwise to decrease speed. Press on the dial to change the direction of travel. Double clicking the pushbutton will pause the slider movement, allowing for manual control. Holding the button for 3 seconds will toggle the LED brightness to allow for night-time operation without a bright, distracting light. Holding the button for 5 seconds will turn off the LED bar completely. It is recommended to do so during long time-lapses in order to save battery.

In order to power the VersaSlider, a DMW-BLF19 rechargeable lithium-ion battery pack is used. With the VersaSlider 3, aftermarket and non-genuine Panasonic battery packs may be used thanks to the improved battery connection method. With the genuine battery pack, the VersaSlider can achieve 12+ hours of constant operation at the 1 blue pixel speed (slowest possible).

Attaching the VersaSlider

- 1) Start off by removing the 8 screws holding the original belt to the two moving carriages. Be careful not to strip the screws. Remove the original belt and save it for later.



- 2) Now unscrew the bottom left leg of the slider. The two pulley wheels may fall out, make sure not to lose them, they will be used in the next step.



- 3) Clip on the VersaSlider body onto the side of the slider. It will snap into place with an audible click and should fit firmly into place. Secure it by screwing the slider leg back in.



- 4) thread the supplied toothed belt into one side of the lower carriage and screw it into place using the holding plate. Thread the other side like the original belt and

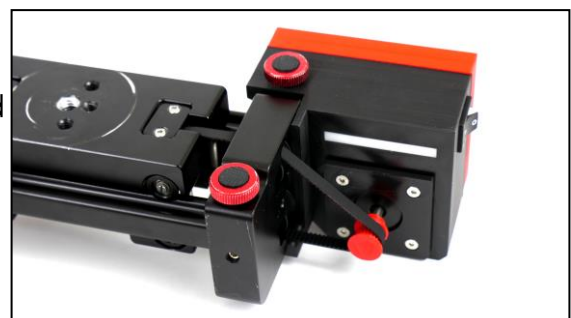

around the VersaSlider's pulley. Make sure that the slider's 2 pulley wheels are in place and have not fallen out. The toothed belt side should face inwards.

- 5) Route the belt under the top carriage's two belt holders but do not secure it yet.



- 6) Secure the other side of the belt to the bottom carriage's other holding plate. Depending on your slider model you may have to cut the belt down to size using scissors. The belt should be reasonably tight to provide enough traction with the pulley.

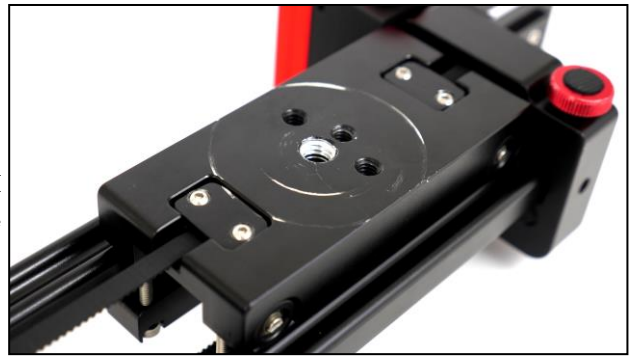

- 7) Finally, move the two carriages to opposite sides of the slider and secure the top carriage's holding plates. This step is done to ensure you get the maximum amount of camera travel.

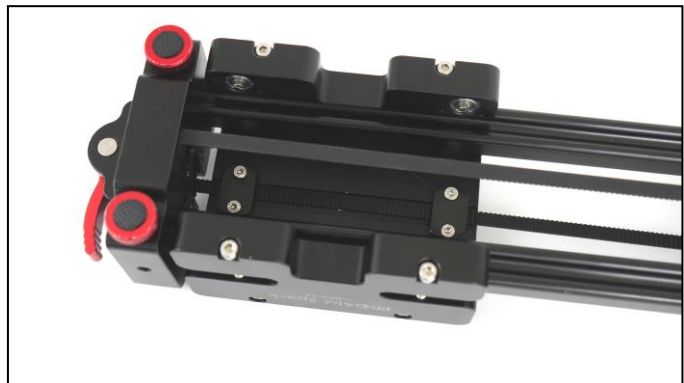

--- Assembly complete ---

Safety

This electronic device or the electrical connections within it are not licensed by any safety organization as of this moment. Do not leave this device unattended and running at any point as lithium-ion batteries can be dangerous and cause fires. Any personal or property damage caused by this device is the user's responsibility. WorkshopScience will not take any responsibility in such an event.

To minimize the risk of the camera mounted on the slider from getting damaged, ensure that a sufficiently sturdy tripod is used and that it does not tip over when the camera is at the end of the slider. If the slider is moving at full speed and reaches the end of the track, a collision will occur and the momentum transferred may move or tip the tripod. Do not leave an unattended VersaSlider 3 running at any time.

There is no low-battery cutoff on the VersaSlider 3 so the user will have to use their judgement to determine whether or not operation should be continued. This can be done by inserting the battery into a compatible camera and seeing the battery level. To prevent damage to the battery from over-discharge, change the batteries fully before every operation. WorkshopScience will not accept any responsibility for ruined batteries due to improper user operation.

Do not run the VersaSlider 3 at maximum speed for extended periods of time as this may result in permanent damage due to overheating of the motor controller. When the camera plate reaches the end of the track, be sure to change the direction otherwise excessive stress is put on the motor.

Physical damage to the VersaSlider 3 from drops or impacts may hinder its operation or render it inoperable. WorkshopScience will not accept any responsibility for damaged parts due to improper user operation. Contact WorkshopScience support at support@workshopscience.com with details to see if the VersaSlider can be repaired.

The slider can be moved manually as long as the VersaSlider 3 attachment is paused. Do not attempt to move it by hand while the motor is running

Do not pull on the speed adjustment knob as this can cause permanent damage to the rotation sensor.

Troubleshooting

issue	reason	solution
VersaSlider not turning on	Incompatible battery Battery improperly secured Battery out of charge	Obtain correct battery Reattach battery Charge battery
Speed dial not reducing speed	Severe impact to the dial or excessive pressure applied	Restart the VersaSlider and move the dial inwards and outwards slightly. After some rotations, the issue will go away
VersaSlider attempting to rotate but slider does not move	Slider movement locked Payload too heavy Angle excessively steep	Unlock the slider Reduce payload Reduce angle
Belt keeps slipping	Belt not tight enough	Sufficiently tighten the belt

TOS

1. Returns are accepted within 14 days of receiving product, buyer pays for return shipping. Shipping to client is non-refundable. A refund will only be given if the item is undamaged and unmodified including all items that originally came in the box.
2. A 2 month warranty is given with the VersaSlider 3. If the device breaks during this time while being operated in normal conditions, a full refund including shipping to client will be given. Warranty is voided if any form of modification has been made or an incompatible power supply was used. Reprogramming or altering the arduino code is classed as a modification.
3. Since many parts that are used in the VersaSlider are 3D printed, small aesthetic imperfections on the surface finish may be present. This is normal and is not a defect. These include extruder movement lines from the 3D printer's head shown here:



4. The RGB bar used to indicate the VersaSlider 3's speed may exhibit slight flickering at high movement speeds due to power limitations. This is normal and is not a defect.